

COMMERCIAL ENTRANCE WITH MEDIAN

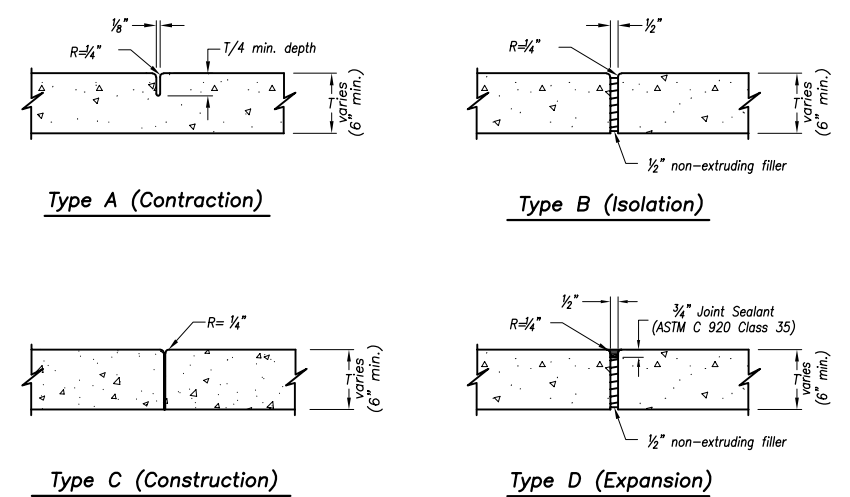

JOINT DETAILS
Not to Scale

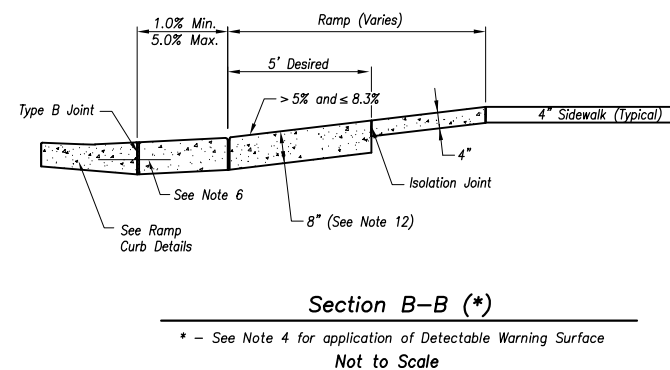
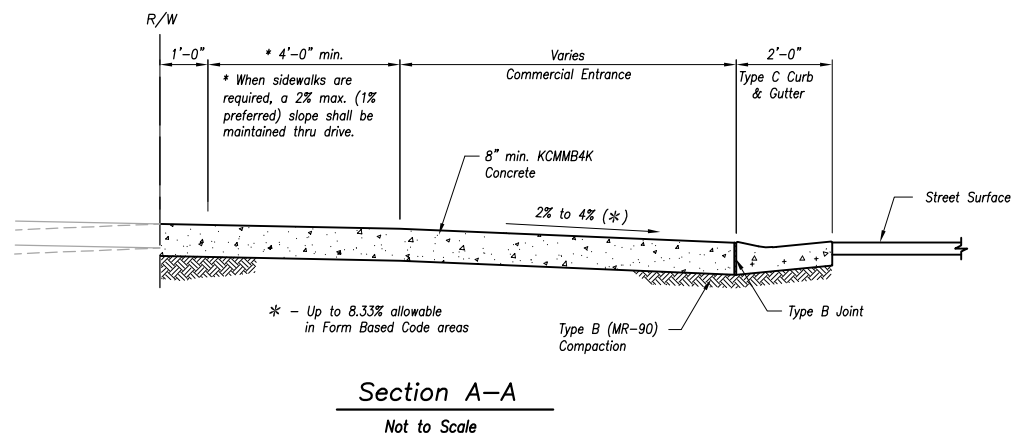
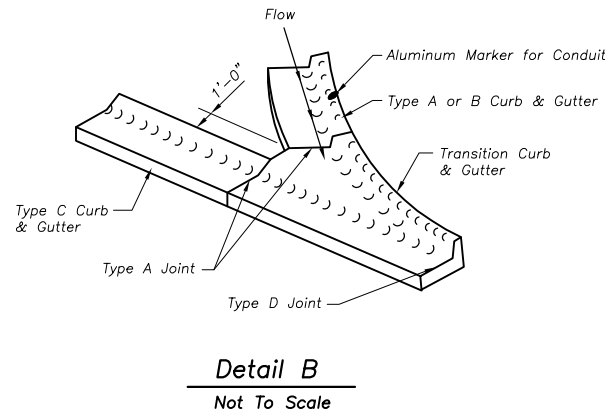
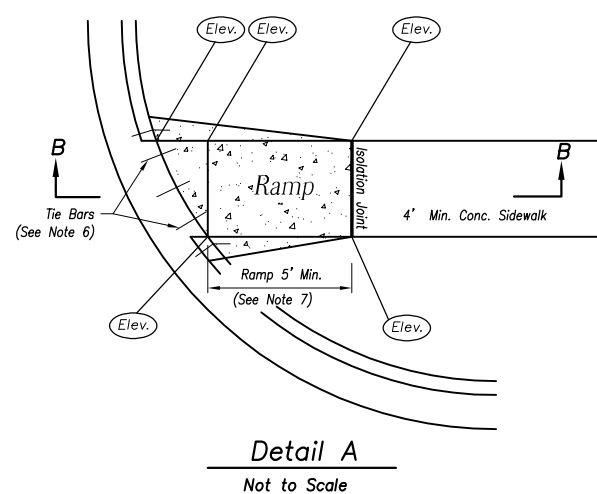

COMMERCIAL ENTRANCE DETAIL

Commercial Drive Notes:

- Overland Park Municipal Code (OPMC) and Overland Park Design and Construction Standards Manual (OPDCSM) are incorporated, except as otherwise noted.
- KCMMB4K Concrete shall be used throughout.
- Concrete pavement shall be jointed with Type A joints. No jointed slab shall exceed 12' x 12'.
- Detectable warning surfaces are not required at non-signalized entrances.
- ADA compliance will be measured at points labeled (Elev.).
- Install 18" tie bars #4 epoxy coated @ 18" o.c. and through wings as shown.
- Sidewalk Ramp shall be lengthened to provide ADA compliant slope, but need not exceed 15'.
- ADA maximum ramp slope = 1"/ft. ADA maximum cross slope = 2%.
- Top of curb elevations shall be shown at quarter points and curb returns.
- Any additional steel reinforcement shall be approved by the City Engineer.
- See Curb Replacement Detail for additional requirements.
- Only 8" thick panels will be paid for as "RAMP". Sidewalk behind isolation joint will be paid for as "4" SIDEWALK".

REVISIONS:		<p>Year 2021 Edition</p> <p>OVERLAND PARK KANSAS</p> <p>ABOVE AND BEYOND. BY DESIGN.</p> <p>DEPARTMENT OF PUBLIC WORKS STANDARD DETAILS</p> <p>COMMERCIAL ENTRANCE DETAIL</p>
Jan. 2005	ADA Compliance;	
Jan. 2009	Joint Locations; Miscellaneous;	
Jan. 2017	Updated ADA Compliance;	
RELATED ORDINANCES:		
OPMC Title 13		
DATE: 08/10/98		
SHEET: 17		