

Fiber Optic General Notes

- All material shall be from The City of Overland Park pre-approved materials list available at City Hall.
- All traffic control in conjunction with the fiber optic construction shall be in conformance with the Manual on Uniform Traffic Control Devices and the Overland Park Traffic Control Handbook for Street Maintenance and Construction Operations, latest revisions.
- The Contractor shall stake the locations for all service boxes to be installed. The stations and offsets provided are to the center of the fiber optic equipment. The contractor shall provide elevations. If obstructions are encountered during installation, the contractor will re-stake those locations affected by the obstruction. The city inspector shall inspect the staking prior to any excavation/construction.
- The locations of existing underground utilities, if shown, are an approximate only and have not been independently verified. The Contractor shall be responsible for contacting all utility companies for locations of all underground lines prior to excavation and be fully responsible for any and all damages, which might occur as a result of the Contractor's failure to exactly locate and preserve any and all underground utilities.
- The City of Overland Park is on the KS One Call system. The contractor shall call 811 to obtain locates for streetlighting, traffic signals, and fiber optic conduits/cables.
- All cables in service boxes and poles shall be identified with color-coded tape as follows:  
 North Cable: Tape Color Code Blue  
 East Cable: Tape Color Code Yellow  
 South Cable: Tape Color Code Purple  
 West Cable: Tape Color Code Red
- The contractor shall be responsible for removing and salvaging existing equipment as noted. See Instructions for Disassembly and Return of Salvaged Fiber Optic Equipment.
- Rock and shale may be encountered and thus the bid items shall reflect the extra work necessary to accomplish the installation. No additional payments ("extras") will be made for excavation of rock or shale and suitable backfill materials. All conduit trenches within rock/shale shall be backfilled with suitable material and properly compacted in accordance with the specifications.
- Conduit shall be bored (by approved methods) in those areas outside of the street improvement limits. Multiple conduits cannot be pulled back through the same bore unless otherwise approved.
- Continuous HDPE (orange) conduit (sized per plan) shall be installed between all service boxes prior to paving within the limits of the street improvements. Conduit splices between appurtenances shall not be allowed unless fusion couplings or other fusion methods are used.
- The conduit placement shall be coordinated with the paving operation, when applicable. Conduit installation and conduit connections shall be inspected and approved by the City inspector. The contractor shall pay any and all extra costs of installing conduits by alternate construction methods after pavement has been placed or for any damages to pavement that may occur during conduit installation. All trenches for conduit under proposed paved surfaces (drives, streets and sidewalks) shall be backfilled with flowable fill unless otherwise directed, to below the proposed pavement surface.
- The conduit shall be installed under underdrain pipe crossings and under the underdrain blankets. Refer to the street plans for underdrain pipe and blanket locations and appropriate details, if applicable.
- All fiber optic fusion splices shall be made at an existing service box made in the presence of the inspector for approval.
- The contractor shall take all precautions necessary to minimize the downtime of the existing systems to be modified. Any existing fiber optic system shall be maintained during construction as long as possible until the new system is installed and operating. The contractor shall coordinate with the Overland Park IT Infrastructure Specialist, (913) 895-6188, two weeks prior to taking any fiber out of service to allow for rerouting of fiber traffic or to obtain splice documents.
- Damage to any existing fiber optic equipment due to the construction shall be the responsibility of the contractor. The equipment shall be replaced or repaired (as directed by the City) with materials equal or better than the existing material.
- All existing fiber optic equipment is to be used in place (U.I.P.) unless otherwise noted in the plans.
- The contractor shall notify the City of Overland Park, KS, Department of Public Works (Bruce Wacker 913-895-6027) of the exact construction schedule so that inspection of the installation can be made.
- The contractor shall be responsible for any damage to existing underground sprinkler systems during construction. All affected pipes or fittings shall be restored to original condition and location with new materials similar to existing. All restoration work shall be acceptable to the engineer and property owner.
- All unpaved areas disturbed or damaged during construction shall be restored to the original condition. Unless otherwise directed, grassy areas shall be re-sodded.
- Contractor shall use a polymer lubricating agent to facilitate conduit bores under paved streets. Failure to do so will result in a denial to retrieve bore head, in the case of loss, under any paved street by excavation methods.
- A 1c#10 AWG THHN/THWN stranded copper locating cable (red) shall be installed in all conduits.

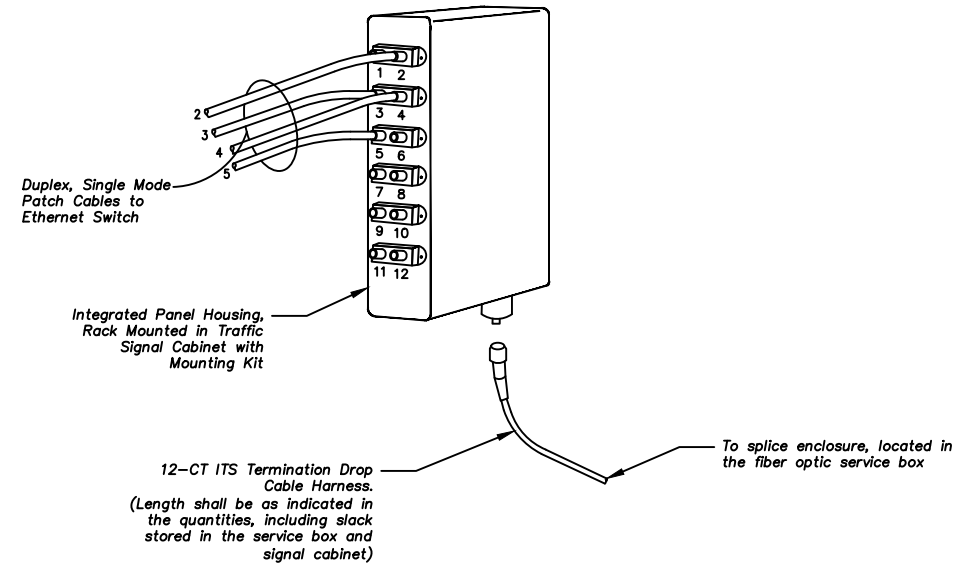

12-CT ITS Termination Drop Cable Assembly

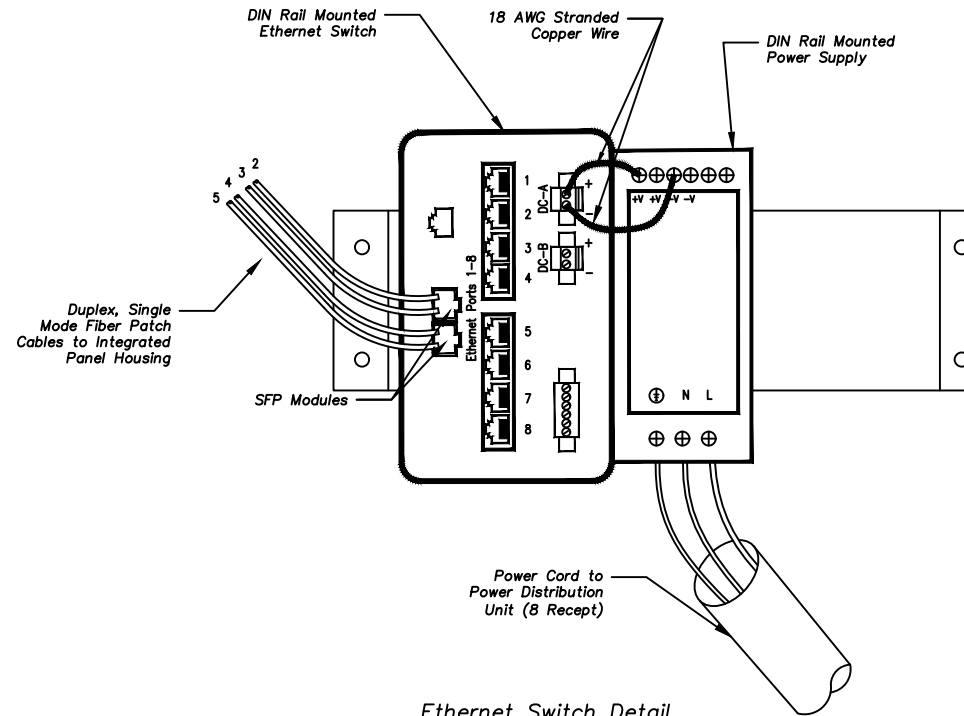

Ethernet Switch Detail

Ethernet Switch Module Port Assignments	
Ethernet Switch*	
Port No.	Assigned Equipment
1	Signal Controller *
2	Cabinet Monitoring Unit (CMU) *
3	Emergency Vehicle Pre-emption (EVP) *
4	Battery Backup / UPS *
5	Presence Radar Detector Interface Module
6	Advance Radar Detector Interface Module
7	Spare
8	CCTV Camera PoE Injector *

Ethernet Switch & Power Supply Details  
(Port Assignments)  
\* Equipment to be programmed by the City

Instructions for Disassembly and Return of Salvaged Fiber Optic Equipment

**For Use on Federal Funded Projects**  
The following is a list of fiber optic equipment which shall be salvaged and stored on site for pickup by the City of Overland Park, unless otherwise instructed by the inspector. All salvaged equipment shall be carefully disassembled and stored. The condition at the time of City pickup shall be the same as prior to removal. The contractor shall notify the City of Overland Park Department of Public Works, Inventory Control Specialist (913) 327-6603 to arrange for the City pickup of the salvaged equipment. Provide 48-hours advance notice.

DELETE WHICHEVER NOTE DOES NOT APPLY TO THIS PROJECT

**For Use on Non-Federally Funded Projects**  
The following is a list of fiber optic equipment which shall be salvaged and returned to the City of Overland Park, unless otherwise instructed by the inspector. The condition at the time of delivery shall be the same as prior to removal. Disassembly of equipment shall be done prior to returning the equipment to the Blue Valley Public Works Maintenance Facility (Traffic Services Maintenance Office and Shop) 6869 W. 153rd Street. The contractor shall notify the City of Overland Park Department of Public Works, Inventory Specialist (913) 327-6603 to arrange for the delivery of the salvaged equipment. Provide 48-hours advance notice.

The City maintains the first right of refusal of any equipment listed. The project inspector will make an on-site assessment to determine if the equipment should be salvaged or disposed. Any equipment that will not be salvaged shall become the property of the contractor.

- All Ethernet switches designated to be removed or replaced shall be removed from the signal cabinet and salvaged. All Ethernet switches mounted with a 19" rackmount kit and an AC power converter shall be salvaged with all items still attached to the rackmount kit. All cables shall be disconnected from the unit.
- All Ethernet video encoders shall be unplugged, all cables disconnected, and salvaged.
- All ITS Termination Drop Cables shall be disconnected at the splice enclosure located in the service box and removed from the conduit back to the control center cabinet. If the lead-in cable cannot be removed from the conduit without damaging, the item should be discarded. All patch cables shall be removed and discarded. The lead-in cable shall be neatly coiled and taped and termination caps re-installed.
- All terminal servers shall be disconnected and salvaged.
- Splice enclosures not designated to be reused shall be removed and salvaged. Existing fiber optic cables shall be cut near the end of the enclosure. It is not necessary to open the enclosure and remove abandoned cable.
- All service boxes and lids shall be removed and salvaged if in good condition.

September 1, 2021, 2:45 PM  
K:\Data\Spec\Detail\_Drawing\Traffic\SD\Inbox\Progress\Current\MASTER SHEETS\2021 Fiber Optic Details - MASTER.dwg  
Miller



**Conduit Marking Detail Notes:**

1. Conduit under all roadway surfaces shall be placed a minimum of 5'-0" below the top of pavement and shall extend to a junction box or service box. Refer to The City of Overland Park Horizontal Directional Drilling Guidelines Handbook, latest edition for further requirements for conduit installation under roadway surfaces. The conduit shall be installed to drain. All ends shall be capped if not used. An aluminum marker shall be placed in the top of the curb directly over the conduit with an approved epoxy. Markers shall be embedded such that the top is flush. Aluminum markers will be furnished by The City of Overland Park.
2. The contractor shall notify the City of Overland Park, Department of Public Works Traffic Services Division, 895-6000, For inspection of the conduit installation by the streetlighting inspector, at least 24 hours notice shall be provided. The conduit shall not be covered so as to ensure proper depth, correct conduit material, and proper conduit end treatment as described above.

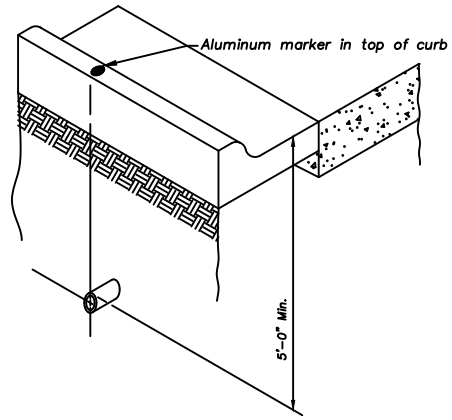

Conduit Marking Detail

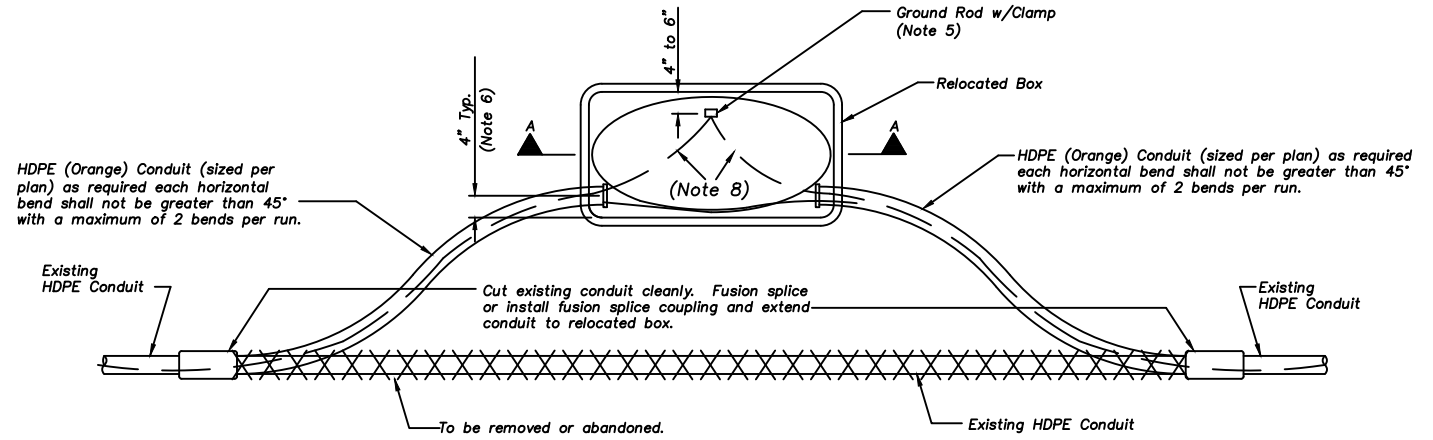

Plan (Conduit Position)  
Relocated Box Installation Detail

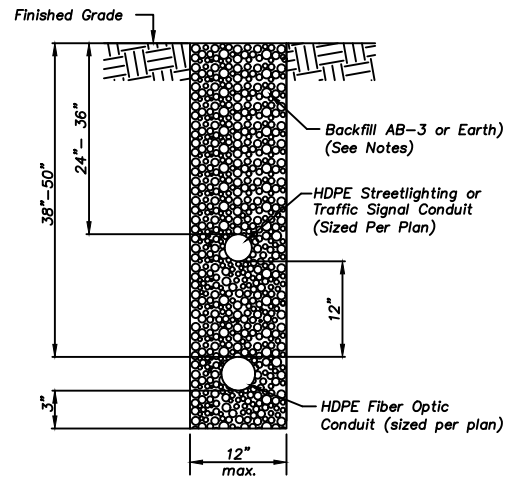

Trench in Unpaved Areas

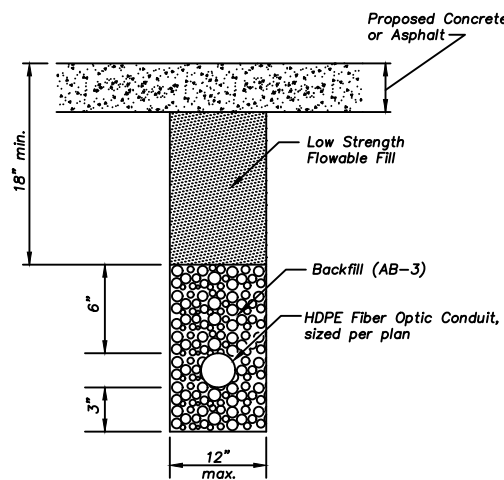

Trench in Proposed Paved Areas

**Trenching Notes:**

1. All trenches for conduit under proposed paved surfaces (drives, streets and sidewalks) shall be backfilled with AB-3 to 6" above the conduit and low strength flowable fill to below the proposed paved surface or existing terrain, unless otherwise directed.
2. Backfill in unpaved areas shall be free of rubble and rock.
3. If multiple conduits are installed, they shall have a minimum of 12" horizontal or vertical clearance between them.
4. Details are typical and information for the separation of multiple conduits are applicable whether trenching in unpaved or paved areas.

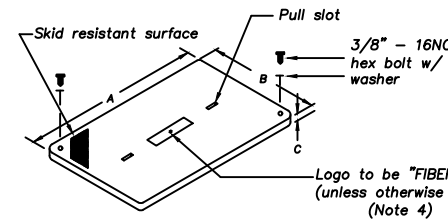
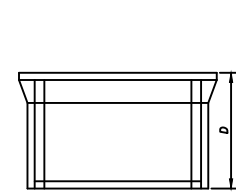

Cover

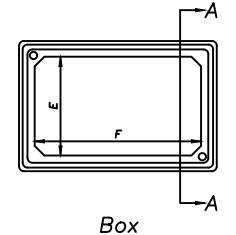

Box

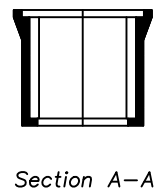

Section A-A

**Notes:**

1. Boxes shall be stackable for extra depth.
2. The "FO" service box and cover shall be rated for no less than 22,500 lbs test load (Tier 15) load per ANSI/SCTE-77.
3. The Type 2 fiber box shall have a two-piece overlapping cover.
4. Cover label shall be attached with an approved epoxy.
5. A 3/8" x 8'-0" ground rod shall be installed in each service box.
6. The conduit shall enter and exit the service box between 38" and 50" and shall be 4" centered off the edge of the service box wall. The fiber cable shall at no time have less than an 8" radius bend.
7. 18" min. layer of 1/2" clean crushed rock shall be constructed below the service box for drainage purposes.
8. 1c#10 AWG THHN/THWN (red) stranded copper locating cable.

Box Type	Approximate Dimensions (inches)					
	A	B	C	D	E	F
Type 1 Fiber	35 3/8	24	3	24	22 1/4	33 7/8
Type 2 Fiber (Note 3)	47 3/8	30 3/8	3	24	28 1/8	45 3/8

Fiber Optic Service Box Details

Plan View



Side View

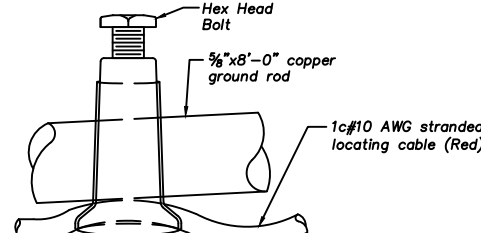

Ground Rod Clamp Connection Detail

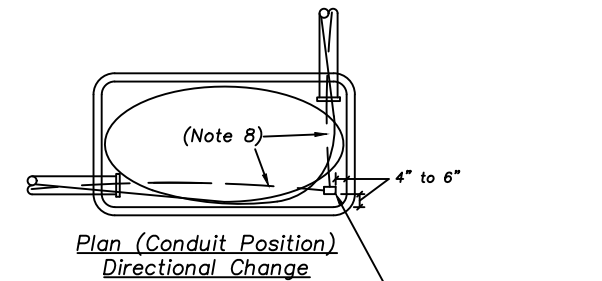

Plan (Conduit Position)  
Directional Change

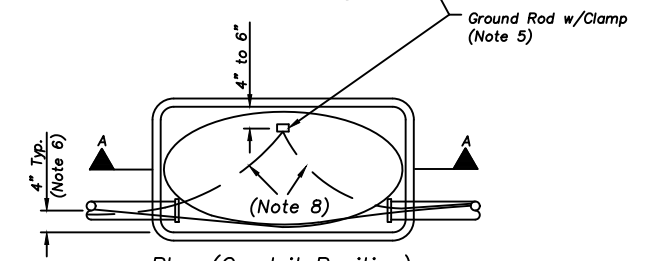

Plan (Conduit Position)  
Straight Through Run

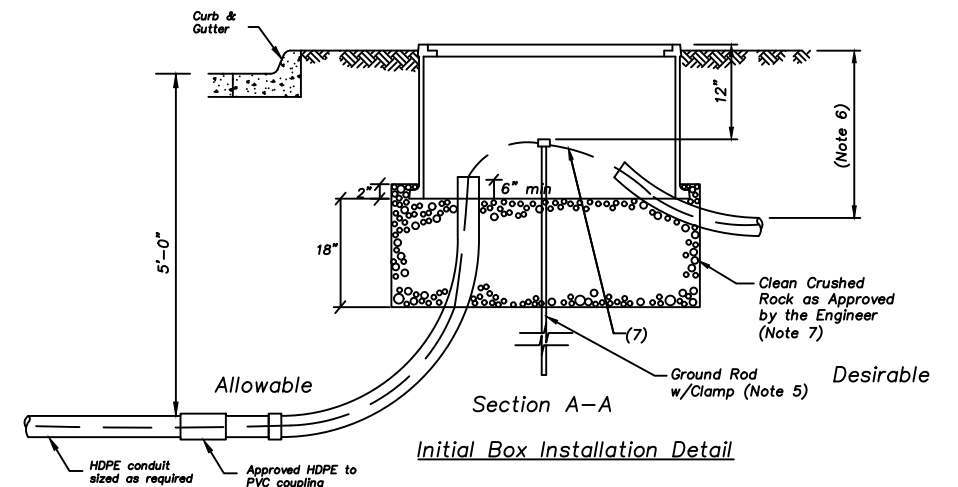

Initial Box Installation Detail