

COMMERCIAL ENTRANCE WITH MEDIAN

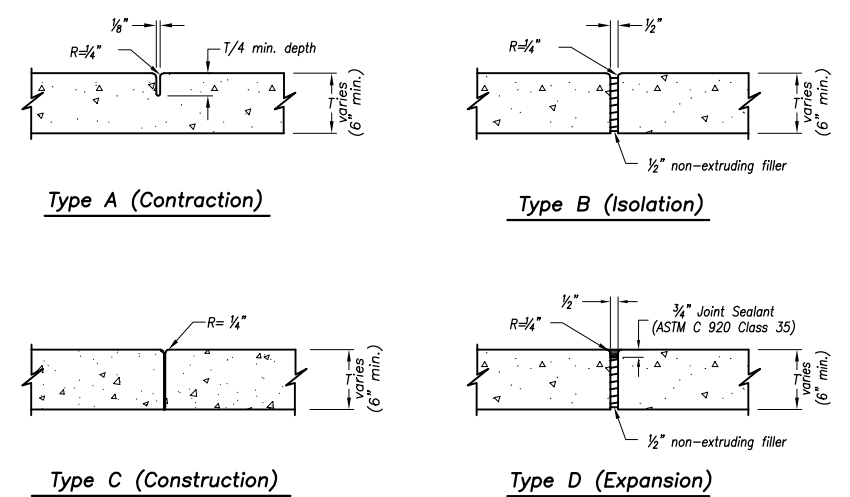

JOINT DETAILS

Not to Scale

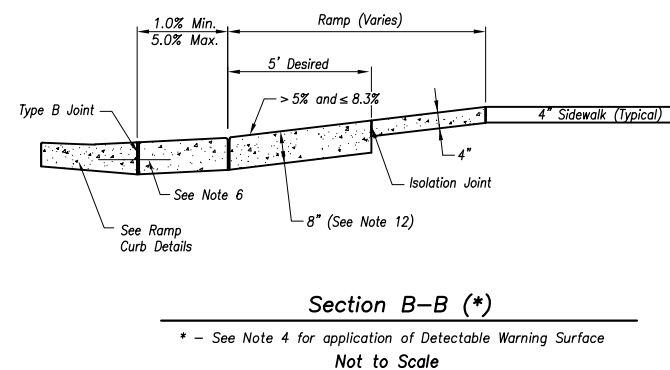
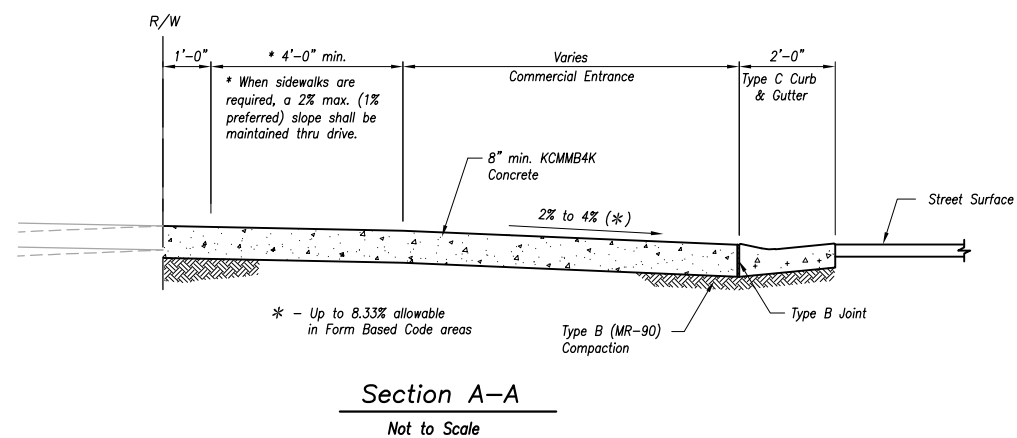
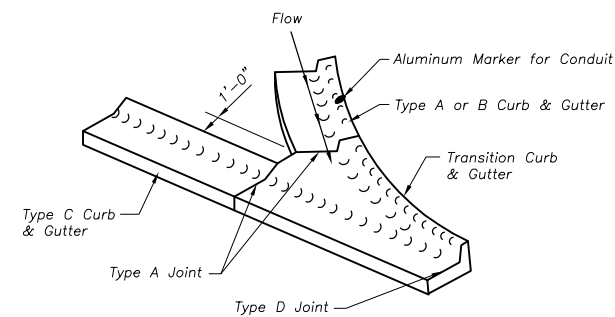
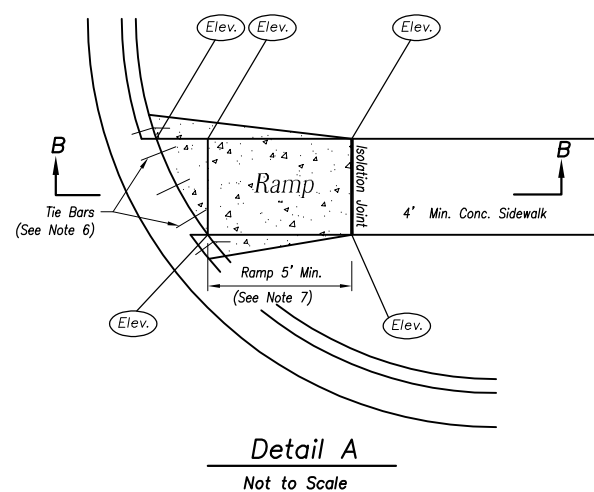

COMMERCIAL ENTRANCE DETAIL

Commercial Drive Notes:

- Overland Park Municipal Code (OPMC) and Overland Park Design and Construction Standards Manual (OPDCSM) are incorporated, except as otherwise noted.
- KCMMB4K Concrete shall be used throughout.
- Concrete pavement shall be jointed with Type A joints. No jointed slab shall exceed 12' x 12'.
- Detectable warning surfaces are not required at non-signalized entrances.
- ADA compliance will be measured at points labeled (Elev.).
- Install 18" tie bars #4 epoxy coated @ 18" o.c. and through wings as shown.
- Sidewalk Ramp shall be lengthened to provide ADA compliant slope, but need not exceed 15'.
- ADA maximum ramp slope = 1"/ft. ADA maximum cross slope = 2%.
- Top of curb elevations shall be shown at quarter points and curb returns.
- Any additional steel reinforcement shall be approved by the City Engineer.
- See Curb Replacement Detail for additional requirements.
- Only 8" thick panels will be paid for as "RAMP". Sidewalk behind isolation joint will be paid for as "4" SIDEWALK".

REVISIONS:	
Jan. 2005	ADA Compliance;
Jan. 2009	Joint Locations; Miscellaneous;
Jan. 2017	Updated ADA Compliance;
RELATED ORDINANCES:	
OPMC Title 13	

Year 2022 Edition

OVERLAND PARK
KANSAS

ABOVE AND BEYOND. BY DESIGN.

DEPARTMENT OF PUBLIC WORKS
STANDARD DETAILS

COMMERCIAL ENTRANCE DETAIL